

Contact Details

Before using the product, please check the guide pages at the front of this catalog.

Internet

<http://www.daikinpmc.com/en/>

For latest information, PDF catalogs and operation manuals

04 Series Stacking Type Port A/B Flow Control Valves

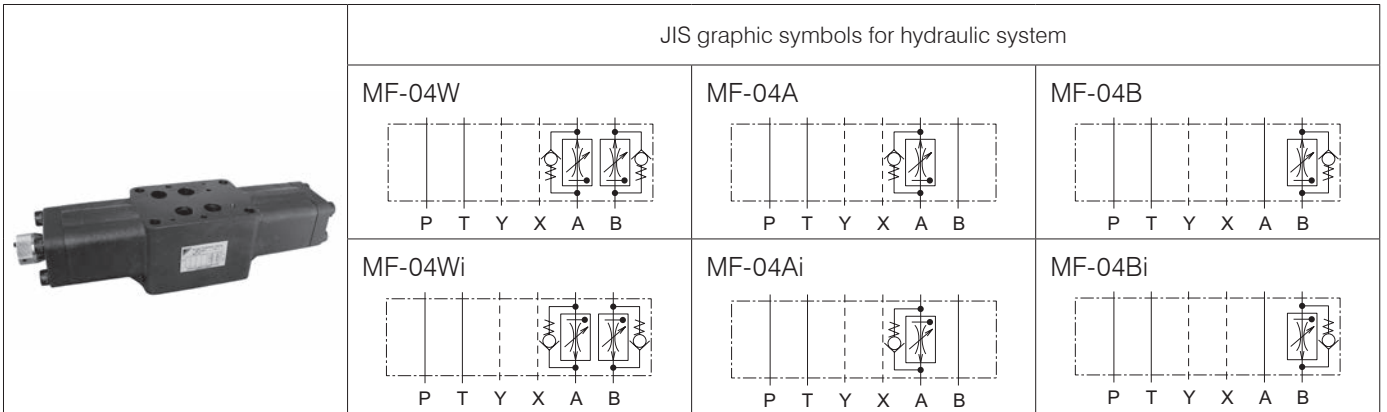

Nomenclature

1 **×** - **MF** - **04** 2 **×** 3 **×** 4 **×** 5 - 6 **×××** - 7 **10**

1 Applicable fluid code

No designation: Petroleum-based hydraulic fluid,
water-glycol hydraulic fluid
F: Phosphate ester hydraulic fluid

2 Model No.

MF: Modular stacking type flow control valve

3 Nominal diameter

04: ½

4 Control port

W: Port A/B A: Port A B: Port B

5 Control method

No designation: Meter-out control
i: Meter-in control

6 Control flow rate

100: 100 L/min
200: 200 L/min

7 Design No. (The design No. is subject to change)

Specifications

Model code	Maximum operating pressure MPa {kgf/cm ² }	Maximum flow rate L/min	Control flow rate *1 L/min			Check valve cracking pressure MPa {kgf/cm ² }	Mass kg
			(1)	(2)	(3)		
MF-04××-100-10	35 {350}	300	10 to 100	15 to 100	20 to 100	0.1 {1}	11
MF-04××-200-10			10 to 200	15 to 200	20 to 200		

Note: *1 Control flow rate (1) Pressure difference between the inlet and outlet ports to be 20.5 MPa {205 kgf/cm²} maximum
(2) Pressure difference between the inlet and outlet ports to be 24.5 MPa {245 kgf/cm²} maximum
(3) Pressure difference between the inlet and outlet ports to be 35 MPa {350 kgf/cm²} maximum

Handling

- To ensure good pressure compensation performance, maintain a pressure difference of 0.8 MPa {8 kgf/cm²} minimum between the inlet and outlet ports for the models with a control flow rate of 100 L/min or 1.5 MPa {15 kgf/cm²} for the models with a control flow rate of 200 L/min.
- The minimum control flow rate is the value when the flow rate fluctuation is within 10% with the pressure compensated.

Performance curves (viscosity: 42 mm²/s {cSt})

Pressure drop characteristics

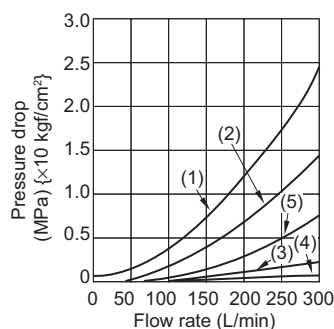

- (1): Port A/B free flow (with handle fully closed)
(2): Port A/B free flow (with handle fully open)
(3): Port T
(4): Port P
(5): Port A/B with no controlling parts (MF-04A, MF-04B)

Pressure - Flow rate characteristics

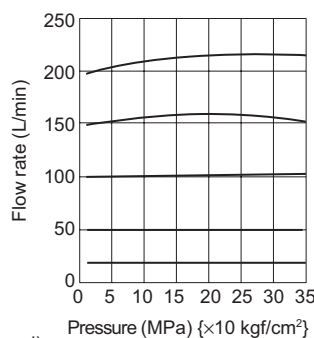

Fluid temperature - Flow rate characteristics

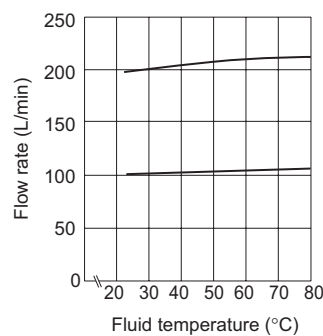

Adjusting handle revolution - Flow rate characteristics

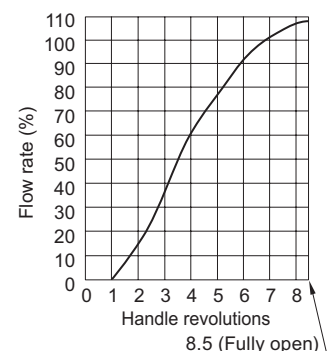

Contact Details

Before using the product, please check the guide pages at the front of this catalog.

Internet

<http://www.daikinpmc.com/en/>

For latest information, PDF catalogs and operation manuals

External dimension diagram

MF-04W

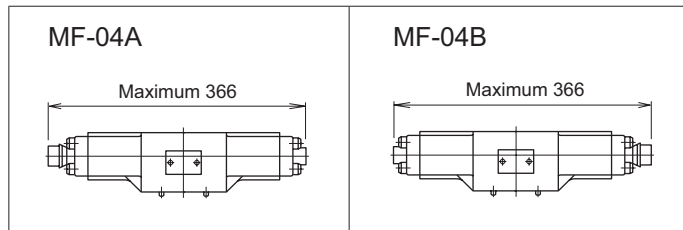
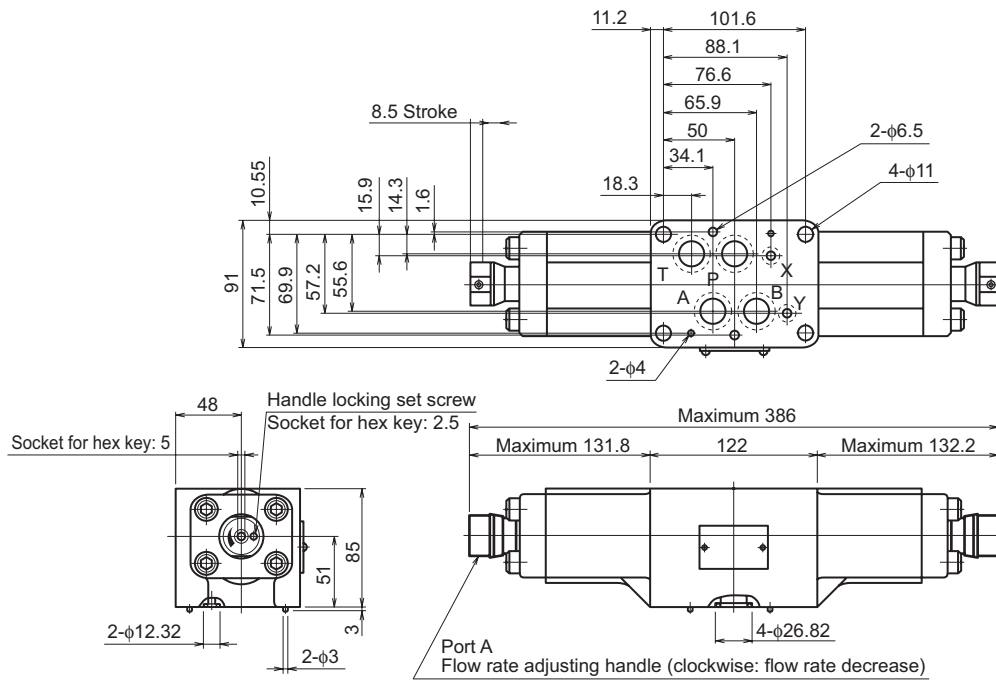

MF-04Wi

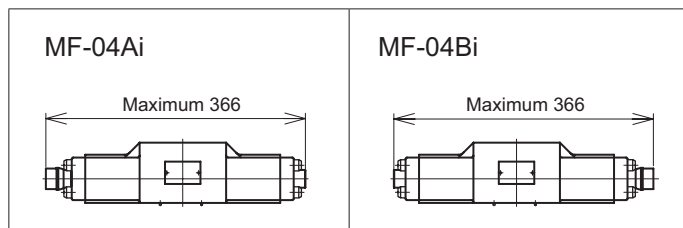
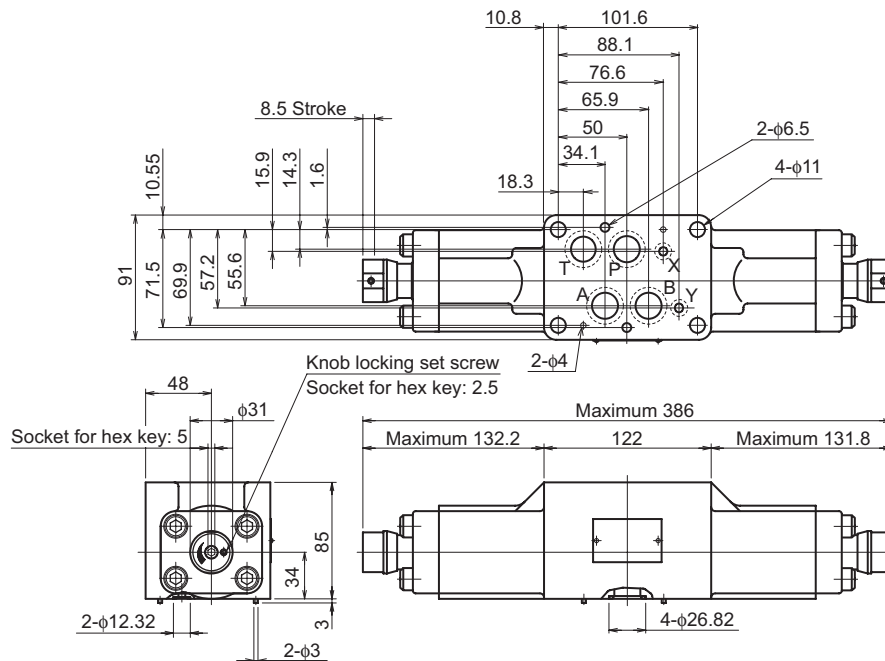

Contact Details

Before using the product, please check the guide pages at the front of this catalog.

Internet

<http://www.daikinpmc.com/en/>

For latest information, PDF catalogs and operation manuals

Sectional structural diagram

MF-04××

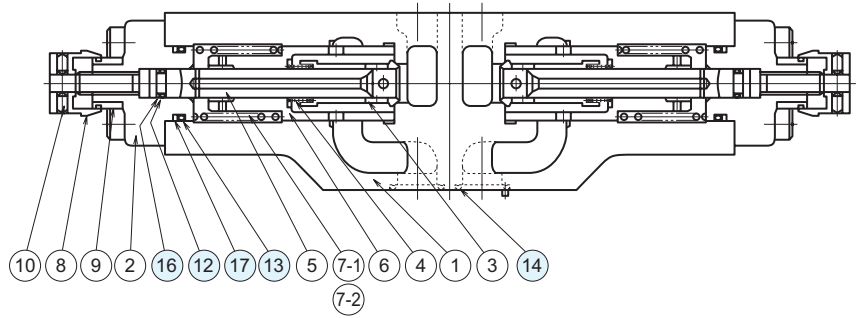
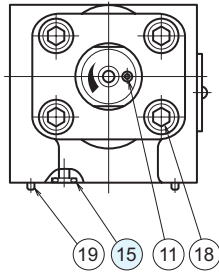

Sealing part table

Part No.	Name	Quantity			Part specifications
		04W(i)	04A(i)	04B(i)	
12	O-ring	2	1	1	JIS B 2401 1BP10A
13	O-ring	2	2	2	JIS B 2401 1BP30
14	O-ring	4	4	4	AS568-118 (NBR, Hs90)
15	O-ring	2	2	2	AS568-012 (NBR, Hs90)
16	Backup ring	2	1	1	JIS B 2407 Bias cut P10A
17	Backup ring	2	2	2	JIS B 2407 Bias cut P30